

MAX MACHINE WORX INC.

WORX MXS-1 BILLET SHIFTER DRIVE



WWW.MAXMACHINEWORX.COM



WORX MXS-1 6061-T6 SOLID BILLET SHIFTER UPPER

SOLID IS WHAT THIS RIPPED BILLET 6061-T6 UPPER IS ALL ABOUT! FEATURING THE WORX CHROMOLY H.P. TOWER, WORX BILLET 1.5" OR 2.0" TOPCAP W/ CHROMOLY TOWER, WORX BILLET REAR STEERING COVER, SOLID STEERING BLOCK, INCREASED CASE WIDTH @ TOP COMBINED WITH THE SOLID NO EXHAUST CAVITY WEDGE I-BEAM CENTER AND LOWER SECTION -, AND THE REINFORCED AND LENGTHENED- INCORPORATED CAV PLATE -

ANODIZED OR SILVER POWDERCOAT FINISH ALLOWS FOR EASY CLEANING AND MAINTENANCE FOR A SOLID, CLEAN APPEARANCE FOR YEARS TO COME. ALSO AVAILABLE IN BLACK.



WORX 2002XS 6061-T6 SOLID BILLET 2.0" SHORTER LOWER GEARCASE

THIS PRECISION SOLID 6061-T6 BILLET LOWER GEARCASE IS THE FASTEST BRAVO CONFIGURATION LOWER ON THE MARKET TODAY! SOME OF THE ADVANCED FEATURES INCLUDE: MACHINED FROM A SOLID CHUNK OF 6061-T6 BILLET vs CAST, HAS 3 GRATE STYLE LOW WATER INTAKE PICKUP --FEATURING STRAIGHT RAM WATER INTAKE, BULLET and LEADING EDGE COFIGURED FOR BEST HYDRODYNAMIC FLOW AVAILABLE, WORX INTERNAL LOWER VERTICAL SHAFT "MAX DUAL BEARING PACK" APPLIES 200% INCREASED PINION GEAR DEFLECTION RESISTANCE FOR STABLE GEAR BACKLASH.*

ALSO INCLUDED IS THE 9" AERO -WEDGE STYLE SKEG FOR THE MOST STEERING CONTROL - WITHOUT SCRUBBING SPEED. EARLY TESTING HAS SHOWN THE OVERALL CONFIGURATION OF THE WORX LOWER CASE TO BE THE MOST EFFICIENT BRAVO CONFIGURATION LOWER CASE YET!!! AVAILABLE AS A COMPLETE LOWER WITH ALL THE RIPPED WORX INTERNALS IN 2.0" SHORTER - 1.26, 1.35, 1.50 RATIO. ALSO AVAILBLE ARE THE MATCHING WORX BILLET SPACER KITS IN 0.5", 1.0", 1.5", 2.0", 2.5" and 3.0" CONFIGURATIONS.*

PART# MMWX-2002XS





PART# MMWX115

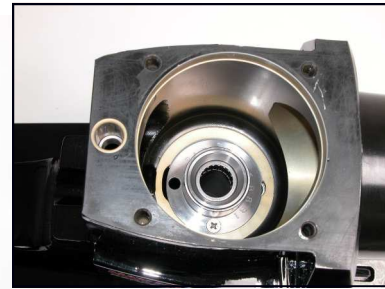

WORX BRAVO UPPER UNIT PARTS KIT

THESE WORX PARTS KITS ARE A COMPLETE UPGRADE KIT FOR ANY BRAVO UPPER COMPRISING OF ALL THE BEST COMPONENTS AVAILABLE TODAY. OVER THE LAST 11 YEARS MAX MACHINE WORX HAS RIGOROUSLY TESTED COMPONENTS IN ALL APPLICATIONS WITH EXCELLENT RESULTS.

THIS KIT INCLUDES THE FOLLOWING – THE PATENTED WORX H.P. TOWER, WORX 2" BILLET TOP CAP, WORX 6X HI-TORK BEARINGS, WORX BILLET TORSIONAL UPPER-CLUTCHSHAFT, WORX BILLET INPUT YOKE OR WORX BILLET X-18 ASSEMBLY OR OEM L-18 U-JOINT ASSEMBLY, WORX BILLET DEEP THREAD SPANNER, WORX BILLET SEAL/O-RING CARRIER, WORX BILLET U-JOINT BEARING SPACER AND THRUST WASHER, WORX BILLET SHIFTER PIN, WORX BILLET TRIM BLOCK, WORX BILLET EXT COUPLER, WORX TREATED OEM XR GEARSET, WORX H.D. 6X UPPER GEAR BEARINGS, WORX H.D. 6X CAGED CLUTCHSHAFT BEARINGS, OEM XR CLUTCH AND CLUTCH THRUST BEARINGS, OEM SHIFT FORK, OEM GIMBAL BEARING, OEM RETAIN RING. TAKE YOUR UPPER UNIT TO THE MAX!

WORX MOD BRAVO UPPER UNIT – COMPLETE

THESE WORX MODIFIED BRAVO COMPLETE UPPER UNITS ARE PRECISION ASSEMBLED BY MAX MACHINE WORX TECHS WITH THE BEST COMPONENTS AVAILABLE TODAY. TRULY A COMPLETE PACKAGE– WITH THE ADVANCED DESIGN, MATERIALS, AND WORKMANSHIP. EACH PARTICULAR COMPONENT BEING DESIGNED SPECIFICALLY FOR ITS JOB IN THE SYSTEM YOU CAN BE CONFIDENT IN OPTIMUM PERFORMANCE UNDER CRITICAL CONDITIONS. THESE UPPER UNITS HAVE BEEN RIGOROUSLY AND THOROUGHLY TESTED UNDER ALL CONDITIONS WITH EXCELLENT RESULTS.

PART# MMWX900-C



WORX H.P. TOWER

THE ORIGINAL TOWER, THIS PRECISION FIT 4130 CHROMOLY STEEL CASE, GEAR, AND BEARING SUPPORT IS UNSURPASSED IN STRENGTH AND RELIABILITY. EXTENDING THROUGHOUT THE UPPER CASE HOUSING AND SECURELY ATTACHED WITH THE BOTTOM SPANNER NUT ASSURES NO SHIFTING OF THE TOWER PIECE OR CRACKING OF THE CASE. THIS IS NOT A PRESS OR SCREW IN TYPE LIKE THE OTHERS ON THE MARKET. DON'T THROW OUT THAT CASE WITH A BROKE CAST TOWER AND BUY A NEW STOCK CASE OR A CASE WITH A TOWER THAT WILL DO THE SAME – FAIL AGAIN. SOLVE YOUR CASE PROBLEMS WITH THE PATENTED H.P. TOWER FITS ALL BRAVO* 1,2,3,X,XZ,XR CASE

WORX BILLET 4130 DEEP THREAD SPANNER NUT

THIS BILLET 4130 CHROMOLY SPANNER NUT FEATURE .040" DEEPER THREAD ENGAGEMENT FOR INCREASED INPUT U-JOINT ASSY HOLDING POWER UNDER HI-TORQ LOADS. FITS WITH BOTH THE OEM L-15 AND L-18 U-JOINT ASSEMBLIES IN THE REGULAR –BRAVO * 1,2,3, X, AND BLACKHAWK.

WORX BILLET 4130 IPC RIGID SEAL CARRIER

THIS BILLET 1PC RIGID SEAL/O-RING CARRIER FEATURES AN ADDED SEAL GUARD FLANGE WHICH PREVENTS THE SEAL FROM BEING PUSHED INTO THE YOKESHAFT DUE TO THE EXTRA OIL PRESSURE FROM THE XR GEARSET. ALSO BEING 1PC NOW FORMS A RIGID BEARING PACK -PREVENTING BEARING PRELOADS FROM CHANGING UNDER HARD LOAD. FITS WITH BOTH L-15 AND L-18 U-JOINT ASSEMBLIES IN THE REGULAR STYLE CASE –BRAVO *1,2,3,X,AND BLACKHAWK DRIVES

WORX BILLET 4130 XR SPANNER/SEAL CARRIER

THIS UNFLEXIBLE BILLET 4130 SPANNER NUT/ SEAL CARRIER FOR THE BRAVO XR CASE HAS THE ADDED SEAL GUARD FLANGE FOR SEAL RETAINMENT WITH THE EXTRA OIL PRESSURE GENERATED BY THE XR GEARSET. MUCH MORE RIGID THAN THE OEM ALUMINUM I FITS BRAVO XZ AND XR CASES.

WORX BILLET 6061T6 TRIM PAD STABILIZER

VITAL FOR HI-SPEED SAFETY - THIS BILLET BLOCK STABILIZES THE UPPER CASE TRIM PADS FROM FLEXING OR BREAKING OFF DUE TO THE EXTREME FORCES FROM TURNING AND WHILE TRIMMED OUT INTURN SAVING AN UNFORTUNATE ACCIDENT OR DAMAGE TO OTHER GIMBAL COMPONENTS. FITS ALL BRAVO 1,2,3,X,XZ,XR DRIVES.

WORX TORTIONAL AEROSPACE ALLOY CLUTCHSHAFT

UTILIZING BILLET TORTIONAL AEROSPACE ALLOYS INSTEAD OF SOFT STAINLESS ALLOWS THE MAX SHAFT TO ABSORB MAXIMUM LOADS AND TORQUE. COMBINED WITH ADVANCED OIL PASSAGES, A LARGER BEARING LOAD SURFACE AND ADDED RADIUS DESIGN, WILL HANDLE HIGHER TORQUE FITS ALL BRAVO 1,2,3,X,XZ,XR AND BLACKHAWK DRIVES.

PART# MMWX225



PART# MMWX227

PART# MMWX228



PART# MMWX250



PART# MMWX250

PART# MMWX310



WORX BILLET 2.0" 6061-T6 TOPCAP w/ WORX BILLET 4340 ALLOY GEAR TOWER

THE WORX TOPCAP HAS ALL OF THE BEST FEATURES AVAILABLE IN A TOPCAP – 2.0 or 1.5" THICKNESS CONFIGURATIONS, 7/16" S.S. STUD KIT, 4340 CHROMOLY STEEL TOWER/THRUST BEARING AREA GIVE THIS CAP THE STRONGEST GEAR SUPPORT AVAILABLE. THE WORX COOLING FINS INCREASE THE SURFACE AREA TO RELEASE THE HEAT TRANSFERRED BY THE UNIQUE CONVECTION COOLING PROCESS – HEAT TRAVELS FROM THE OIL TO THE STEEL TO THE ALUMINUM, TO THE FINS, TO THE SHOWER WATER – SO THE CAP IS CONSTANTLY PULLING HEAT FROM THE OIL - WITHOUT SACRIFICING STRUCTURAL INTEGRITY FROM DRILLING PASSAGES THRU THE CAP. THERE IS NO COMPARISON – SEE THE MAX DIFFERENCE !!

PART# MMWX230



PART# MMWX600

PART# MMWX602

WORX PERF STAINLESS DRIVE SHOWER KITS – FLEX, RIGID, or OFFSHORE

THESE WORX DRIVE SHOWERS ARE CONSTRUCTED FROM QUALITY STAINLESS STEEL AND POLISHED TO MIRROR FINISH. INCLUDED IS EITHER THE WORX 3/8" Or 7/16" DEEP STUD, NUT, WASHER KIT, BRAIDED S.S. HOSE or POLISHED S.S. RIGID HARD LINE, & WORX BILLET 6061-T6 SPACERS. ALSO AVAILABLE IN I.T.S. LATHAM, WPM, STEERING CONFIGURATIONS.

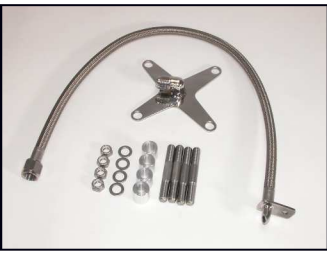

	RPM	FT.LB. LOAD
WORX 6X CLUTCHSHAFT BEARING	18000	12500
OEM CLUTCHSHAFT BEARING	4400	4800
WORX 6X GEAR TOWER BEARING	8600	11650
OEM TOWER BEARING	3300	8000
WORX 6X GEAR THRUST BEARING	6400	14600
OEM THRUST BEARING	4400	6060

WORX 6X HI-TORK PRECISION BEARINGS

THESE WORX EXCLUSIVE UPPER UNIT BEARINGS ELIMINATE THE EXCESSIVE AXIAL AND RADIAL MOVEMENT OF THE COMPONENTS INSIDE THE UPPER UNIT. DESIGNED TO HANDLE HI-SPEEDS AND LOADS – UP TO 6 X AS MUCH AS STOCK OR OTHER AFTERMARKET BEARINGS. THE WORX BEARINGS' PRECISION TOLERANCES ELIMINATE MULTIPLE FAILURES SUCH AS GEAR BACKLASH INCREASE UNDER HARD LOADS. SEE THE BEARING COMPARISON CHART.



WORX BILLET TORSIONAL U-JOINT ASSEMBLIES

THESE WORX PERFORMANCE BILLET TORSIONAL ALLOY U-JOINT ASSEMBLIES COME IN BOTH L-15 ORIGINAL REG AND L-18 ORIGINAL XR SIZES AND ARE BEEFED UP WITH EXCLUSIVE INTERNAL WEBBING FOR MAX STRENGTH AND ARE AN EXCELLENT UPGRADE FOR THE BRAVO DRIVE. AVAILABLE IN THE I.T.S. LONG SHAFT CONFIGURATION AS WELL.



PART# MMWX317COMP

PART# MMWX315COMP

WORX TREATED OEM XR 3PC GEARSETS

THESE WORX TREATED OEM XR GEARSETS ARE NEAR-NET FORGED FOR THE STRONGEST MATERIAL GRAIN STRUCTURE AVAILABLE TODAY. DEBURRED, AND INSPECTED BY MAX MACHINE WORX ASSURE THE HIGHEST QUALITY AND PERFORMANCE. WITH THE ADDED WEB @ THE ROOT OF EACH TOOTH THESE GEARS ARE STRONGER BY DESIGN. IN STOCK AND AVAILABLE FOR ALL BRAVO AND BLACKHAWK DRIVES TODAY!



PART# MMWX410

WORX HI-TORK BILLET INPUT YOKE & THRUST WASHER, SPACER

THIS BILLET TORSIONAL ALLOY INPUT YOKESHAFT IS DESIGNED TO COMBINE THE REG L-15 U-JOINT ASSEMBLY AND MATE TO THE XR 18 SPLINE PINION GEAR FOR XR GEAR UPGRADE INTO A REGULAR BRAVO UPPER CASE. OTHER WORX PARTS INCLUDE THE BILLET 8620 ALLOY STEPPED THRUST WASHER & TRUE RIGID U-JOINT BEARING PRELOAD & BACKLASH SHIM KIT, WORX BILLET 8620 ALLOY U-JOINT BEARING SPACER, WORX 6X HI-TORK PINION NUT & WASHER.



PART# MMWX315



PART# MMWX410



PART# MMWX426



WORX PERFORMANCE OEM BRAVO LOWER UNIT—COMPLETE and HOUSINGS

THESE MAX MACHINE WORX PRECISION ASSEMBLED COMPLETE RACE LOWERS UTILIZE THE WORX BILLET TORTIONAL AEROSPACE ALLOY SHAFTS — THE ONLY TRULY TORTIONAL SHAFT ON THE MARKET TODAY , ABSORBING UP TO 35% OF THE LOAD FROM BEING TRANSFERRED TO OTHER COMPONENTS IN THE DRIVE. AVAILABLE IN REGULAR SIZES ALSO THE 1/4" LARGER PROPSHAFT SIZES TO CUSTOM MEET YOUR DEMANDS.

ALSO INCLUDED IS THE BILLET PROPSHAFT CARRIER ,LARGER PROPSHAFT BEARING FOR MAXIMUM SHAFT STABILIZATION . ALSO AVAILABLE WITH THE STANDARD CARRIER AND BEARING IF REQUESTED. ALL WORX LOWERS COME STANDARD WITH NET-FORGED GEARSETS. THESE NET FORGED GEARSETS ARE ABSOLUTELY THE STRONGEST GEARSETS DUE TO THE GRAIN STRUCTURE SUPERIORITY (THE GRAIN OF THE METAL IS NOT CUT THROUGH TO FORM THE SHAPE OF THE GEAR TEETH AS IT IS IN A BILLET GEAR) THE GRAIN IS THE SHAPE OF THE TOOTH RESULTING IN A MUCH STRONGER GEAR — THEN TO TAKE IT TO THE MAX THE OEM GEARS ARE RECARBURIZED (CASE HARDENED) TO .060"-.080' DEEP - TWICE AS DEEP FOR ELIMINATION OF THE PITTING PROBLEMS .

THESE FACTORS RESULT IN A SUPERIOR PERFORMING LOWER UNIT . AVAILABLE WITH REGULAR OR LOW WATER NOSECONE AND YOUR CHOICES OF GEAR RATIOS 1.50, 1.35, OR 1.26



PART# MMWX220

PART# MMWX758



PART# MMWX750

**WORX BRAVO 1 LOWER UNIT PARTS KIT**

THIS KIT INCLUDES : WORX BILLET LOWER TORTIONAL AEROSPACE ALLOY VERTICAL SHAFT AND EITHER THE WORX 1.00" OR 1.250" PROPSHAFT. YOUR CHOICE OF BILLET OR OEM PROPSHAFT CARRIER WITH SPANNER NUT, TAB WASHER, SPACER, LOAD RING OR RIGID SHIM PACK . ALSO INCLUDED IS THE WORX 6X HI-TORX PINION NUT AND WASHER, ALL TIMKEN PERFORMANCE BEARINGS, RACES, AND SHIM PACKS . ALSO INCLUDED IS THE NEAR-NET FORGED LOWER GEAR SET IN YOUR CHOICE OF 1.50, 1.35, OR 1.26 RATIOS. OPTIONAL REGULAR AND LOW WATER PICKUP BULLETS AND CASE HOUSINGS ALSO AVAILABLE .

WORX H.D. & REG LOWER BEARING KITS

THESE H.D. & REG LOWERS BEARING KITS FEATURE THE LARGEST BEARINGS AVAILABLE FOR THE BRAVO* CONFIGURATION LOWER CASES . USING ONLY HIGH QUALITY TIMKEN, INA, TORRINGTON, SKF, or RBC YOU CAN BE ASSURED THESE ARE NOT CHEAP REPLACEMENTS. LOWER VERTICAL SHAFT ROLLER NEEDLE BEARINGS COME CAGED STYLE IN THE H.D. KIT AND FULL COMPLEMENT STYLE IN THE REG KIT. ALL BEARINGS IN STOCK AND AVAILABLE SEPERATELY.



WORX BILLET TORTIONAL AEROSPACE ALLOY VERTICAL SHAFTS

THESE WORX EXCLUSIVE TORTIONAL ALLOY VERTICAL SHAFTS HAVE BEEN RIGOROUSLY TESTED TO 1300 H.P. IN ALL TYPES OF CONDITIONS AND HAVE SHOWN THE ABILITY TO ABSORB UP TO 35 % OF THE LOAD BEING TRANSFERRED TO OTHER DRIVE TRAIN COMPONENTS WITH EXCELLENT RESULTS. THESE SHAFTS ARE ALSO HEAT TREATED AND ELECTROLESS NICKEL PLATED. THERE IS NO OTHER SHAFT ON THE MARKET THAT COMPARES. AVAILABLE IN BOTH 1" AND 1 1/4" DIAMETER AND 1, 2, 3" SHORTER LENGTHS AND ALSO XR STYLE BOLT CONFIGURATION. ALSO OFFERED IS THE BILLET TORTIONAL BLACKHAWK VERTICAL SHAFT!

MMWX301 REG
MMWX302 XR - NUT
MMWX303 XR - BOLT



WORX BILLET TORTIONAL AEROSPACE ALLOY PROPSHAFTS

THESE WORX BILLET CNC PROPSHAFTS UTILIZE THE SAME EXCLUSIVE TORTIONAL ALLOYS USED IN ALL MAX MACHINE WORX SHAFTS. BY FAR THE MOST ADVANCED SHAFTS ON THE MARKET TODAY. HEAT TREATED AND STRESS RELIEVED FOR MAX DURABILITY - THESE SHAFTS ABSORB REPEATED SHOCK LOADS -AVAILABLE IN YOUR CHOICE OF 1" OR 1 1/4".



PART# MMWX306

WORX BILLET 6061-T6 REG & H.D. PROPSHAFT CARRIERS

THESE WORX BILLET CARRIERS ARE IN STOCK AND AVAILABLE IN THE OEM REGULAR BEARING, OEM XR BEARING AND ALSO IN THE LARGER WORX BEARING CONFIGURATIONS.



PART# MMWX336-1 REG
PART# MMWX336-2 XR



PART# MMWX420

WORX TREATED OEM NET-FORGED LOWER GEARSETS

THE OEM NEAR-NET FORGED LOWER GEARSETS UTILIZE THE ADVANCED STRUCTURAL DESIGN OF THE ACTUAL MATERIAL GRAIN - THE GRAIN FLOWS WITH THE ACTUAL SHAPE OF THE GEAR TOOTH INSTEAD OF BEING CUT THROUGH AS WITH A BILLET GEAR. THIS FACT COMBINED WITH THE ADDED FLOOR DESIGN @ THE ROOT OF EACH TOOTH - NOT AVAILABLE WITH A CUT OR SHAPED TOOTH - INCREASES THE LOAD THAT CAN BE APPLIED TO THE TEETH.

THEN THESE OEM SETS ARE CHECKED @ THE ENGAGEMENT SURFACE OF THE ACTUAL TOOTH - ALL THE WAY AROUND THE GEAR FOR ANY OUT OF ROUND CONDITIONS, THEN ANNEALED, RECARBURIZED -(CASE HARDENED) TO A DEPTH OF .060-.080", HARDENED, STRESS RELIEVED, AND FINISH BLASTED FOR A TECHNOLOGICALLY SUPERIOR GEARSET. AVAILABLE IN 1.50, 1.35, OR 1.26 RATIOS.



PART# MMWX422

WORX 17-4 STAINLESS STEEL GIMBAL RINGS

THESE 17-4 STAINLESS STEEL H.D. GIMBAL RINGS HAVE AN UNMATCHED TENSILE STRENGTH OF ALL AVAILABLE BRAVO* RINGS ON THE MARKET TODAY. UTILIZING THE EARLY GUSSETED DESIGN THESE ARE THE STRONGEST DESIGN OF ALL BRAVO* RINGS. ALSO INCLUDED ARE THE WORX H.D. DELRIN OR SAE 841 OIL IMPREGNATED BRONZE H.D. BUSHINGS AND AVAILABLE ARE THE MIL SPEC 300 S.S. 1/4-20 GIMBAL HINGE PIN BOLTS FOR SUPERIOR 180,000 PSI MINIMUM TENSILE STRENGTH .DESIGNED TO WORK WITH MOST STEERING AND THE OEM H.P. HARDWARE. SOLVE YOUR GIMBAL RING ISSUES !!
**** SPECIAL ORDER ONLY

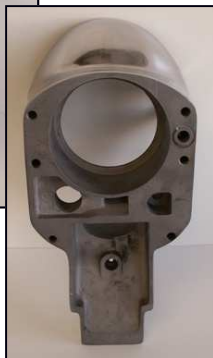

WORX 17-4 STAINLESS STEEL H.D. GIMBAL HELMETS

THESE 17-4 STAINLESS STEEL H.D. GIMBAL HELMETS ARE THE BRAVO HELMET CONFIGURATION AT IT'S STRONGEST. POLISHED AND CUSTOM FIT WITH ULTRA HEAVY DUTY SAE 841 OIL IMPREGNATED BRONZE BUSHINGS OR DELRIN H.D. 1.125" BUSHINGS - AT 1.125" THESE BUSHINGS ARE A FULL 1/8 TH INCH LARGER THAN OEM OR OTHER AFTERMARKET HELMETS . THEY ARE DEFINITELY DESIGNED TO HANDLE THE POWER AND TORQUE FROM TODAY'S POWERPLANTS . AVAILABLE IN H.P. PIN CONFIGURATION ONLY.
**** SPECIAL ORDER ONLY

WORX BILLET 6061-T6 REGULAR & SPORTMASTER SPACER KITS 0.5" , 1.0" , 1.5" , 2.0"

THE WORX BILLET SPACER KITS ALLOW FOR CUSTOM DRIVE HEIGHT MODIFICATION BY THE HALF INCH FOR MAX PERFORMANCE. AVAILBLE IN - 0.5" , 1.0" , 1.5" , 2.0" , 2.5" , and 3.0" LENGTHS AND IN THE REG STYLE (FULL LENGTH) AND ALSO IN THE WORX PERFORMANCE STYLE (SHORT - CUT OFF LENGTH) - MATCHING THE WORX BILLET LOWER and ALSO THE OEM SPORTMASTER. THE KITS INCLUDE ALL NECESSARY HARDWARE , O-RINGS , STUD KTI , AND THE WORX BILLET TORTIONALEXT COUPLER - AND ARE AVAILABLE IN WORX POLISHED CLEAR ANODIZE ALUMINUM and WORX BLACK ANODIZE FINISHES .

PART# MMWX1050-0.5
PART# MMWX1050-1.0
PART# MMWX1050-1.5



PART# MMWX1060-1.0



PRICING : OUR POLICY IS TO GIVE OUR DEALER DISCOUNT TO ANY LEGITIMATE MARINE COMPANY , INCLUDING BOAT MANUFACTURERS , BOAT REPAIR SHOPS , ETC . BEFORE THIS DISCOUNT IS EXTENDED , PROOF OF THE ABOVE WILL BE REQUIRED . TO QUALIFY , WE REQUIRE THE FOLLOWING :

1. COPY OF CURRENT SALES TAX CERTIFICATE
2. COMPANY LETTERHEAD
3. BUSINESS CARD
- 4 . PHONE BOOK AD

POSSESSION OF OUR PRICE LIST DOES NOT CONSTITUTE QUALIFICATION TO PURCHASE AT A DISCOUNT . PRICES AND TERMS SUPERSEDE ALL OTHER AND ARE SUBJECT TO CHANGE WITHOUT NOTICE . PRICES DO NOT INCLUDE SHIPPING AND HANDLING FEES .

TERMS : RETAIL AND NEW ACCOUNTS ARE C.O.D. , CASH OR CASHIERS CHECK/ MONEY ORDER . INTERNATIONAL ORDERS MUST BE PREPAID BY WIRE TRANSFER . PERSONAL AND COMPANY CHECKS ARE ACCEPTED , BUT MUST CLEAR BEFORE PRODUCT IS SHIPPED .

SHIPPING : ALL ORDERS ARE SHIPPED UPS GROUND SERVICE UNLESS OTHERWISE SPECIFIED . UPS AIR ,AND TRUCK LINES ARE ALSO AVAILABLE . DAMAGE DUE TO SHIPPER IS NOT THE RESPONSIBILITY OF MAX MACHINE WORX , INC . SHIPMENT DAMAGE CLAIMS MUST BE MADE DIRECTLY WITH THE FREIGHT CARRIER. DO NOT RETURN DAMAGED PRODUCTS TO MMWX — SUCH SHIPMENTS WILL NOT BE ACCEPTED .
EXPEDITING CHARGES ARE AS FOLLOWS : 1. OVERNIGHT SHIPMENTS WILL BE ASSESSED \$25.00
2. SECOND DAY SHIPMENTS WILL BE ASSESSED \$ 10.00

FAX ORDERS : WE ARE HAPPY TO ACCEPT ORDERS THAT ARE SENT TO OUR FAX NUMBER — 928 505 6421 . PLEASE FOLLOW -UP WITH A CALL TO CONFIRM THAT THE ORDER WAS RECEIVED BY MMWX .

SPECIAL ORDERS : 25 % DEPOSIT IS REQUIRED ON ALL CUSTOM MANUFACTURED OR SPECIAL ORDERS . NO RETURNS ON THESES ORDERS — NO EXCEPTIONS .

BACK ORDERS : PARTS NOT AVAILABLE FOR IMMEDIATE SHIPMENT WILL BE PLACED ON BACK ORDER AND SHIPPED AS SOON AS POSSIBLE .

CLAIMS : CLAIMS FOR SHORTAGES OR ERRORS IN SHIPMENT MUST BE MADE WITHIN 3 DAYS OF RECIEPT OF SHIPMENT AND MUST INCLUDE A COPY OF THE INVOICE .

RETURNED ITEMS : NO RETURNED ITEMS WILL BE ACCEPTED FOR CREDIT UNLESS AUTHOURIZED BY MMWX . FREIGHT MUST BE PREPAID AND A COPY OF THE INVOICE MUST BE INCLUDED . ALL RETURNED ITEMS ARE SUBJECT TO A 30 % RESTOCKING CHARGE . SCRATCHED , DAMAGED OR INCOMPLETE PARTS WILL BE CHARGED AT A HIGHER RATE AT OUR DISCRETION . CUSTOMER IS RESPONSIBLE FOR ADEQUATE PACKAGING OF RETURNED PARTS.

WARRANTY : MMWX PRODUCTS ARE WARRANTED TO BE FREE OF DEFECTS IN MATERIALS AND WORKMANSHIP AT TIME OF DELIVERY . ALL DEFECTIVE COMPONENTS MUST BE RETURNED TO MMWX WITHIN 14 DAYS OF RECIEPT OF SHIPMENT. MMWX WILL , AT ITS DESCRETION , REPAIR OR REPLACE SAID COMPONENT IF EVALUATION PROVED DEFECTS IN MATERIAL OR WORKMANSHIP.

MMWX WILL IN NO WAY BE LIABLE FOR MORE THAN THE COST OF THE ORIGINAL PRODUCT . UPON INSTALLATION , THERE IS NO WARRANTY STATED OR IMPLIED DUE TO THE EXTREME AND UNUSUAL STRESSES PLACED ON HIGH PERFORMANCE AND RACING PARTS , AND WE HAVE NO CONTROL OVER HOW THESE PARTS ARE INSTALLED AND USED . OEM XR GEARSETS ARE NOT COVERED , OEM MERCUISER PARTS ARE NOT COVERED . SHIPPING COSTS ARE THE OWNERS RESPONSIBILITY

WARNING : DRIVE SYSTEMS AND COMPONENTS ARE SUBJECT TO EXTREME ABUSE . IT IS THE OPERATORS RESPONSIBILITY TO CHECK ALL DRIVE COMPONENTS , INCLUDING PROP AND GEARLUBE , PRIOR TO EVERY OPERATION . MMWX DOES NOT ENCOURAGE OR CONDONE THE COMBINATION OF OUR DRIVE COMPONENTS WITH THOSE OF OTHER MANUFACTURERS EXCEPT OEM MERCUISER . MMWX SYSTEMS ARE NOT NECESSARILY TRANSFERABLE FROM ONE APPLICATION TO ANOTHER AND MAY CONSTITUTE A HAZARD IF USED INCORRECTLY .

IF YOU HAVE ANY QUESTIONS PLEASE CALL 928-505-7860

BRAVO and MERCUISER ARE REGISTERED TRADEMARKS OF THE BRUNSWICK CORPORATION

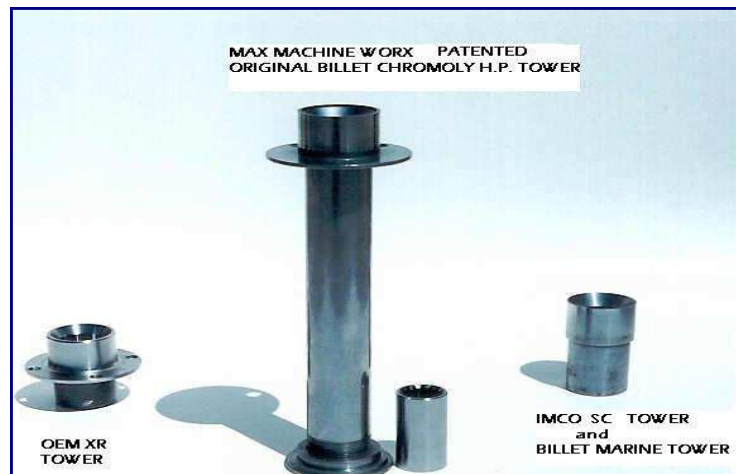

WORX PERFORMANCE CUSTOMERS

2010 DESERT STORM SHOOTOUT – 1ST PLACE UNLIMITED SINGLE DECKBOAT
2009 DESERT STORM SHOOTOUT - 1ST PLACE UNLIMITED SINGLE DECKBOAT
2008 DESERT STORM SHOOTOUT – 1ST PLACE UNLIMITED SINGLE DECKBOAT
2009 LAKE RESCUE SHOOTOUT – 1ST PLACE UNLIMITED SINGLE ENGINE DECKBOAT
2008 LAKE RESCUE SHOOTOUT – 1ST PLACE UNLIMITED SINGLE ENGINE DECKBOAT
BOAT SPECS : 2007 HOWARD 28FT SPORTDECK - 572CID W/ 8.0L WHIPPLE
TOP SPEED 118 MPH
DRIVE SPECS : MAX MACHINE WORX – MMWX900 UPPER / LOWER 1.35 RATIO



2008 DESERT STORM SHOOTOUT - 1ST PLACE UNLIMITED SINGLE ENGINE VEE
PERFORMANCE BOATS MAGAZINE "FASTEST SINGLE ENGINE VEE- EVER TESTED"

BOAT SPECS : 2007 HOWARD 28FT BULLET - 598 CID W/WHIPPLE 5.0L
1345 HP / 1320 FT LBS TOP SPEED 130.1 MPH

DRIVE SPECS : MAX MACHINE WORX – MXS-1 BILLET UPPER / MMWX2002XS LOWER



WORX PERFORMANCE CUSTOMERS

2005 LAKE RESCUE SHOOTOUT - 1ST PLACE UNLIMITED SINGLE ENGINE CAT

BOAT SPECS : 25 ELIMINATOR DAYTONA 605 CID W/ 14-71 BLOWER
1385 HP / 1350 FT LBS TOP SPEED : 132 MPH

DRIVE SPECS : MMWX900 UPPER / WORX BILLET 2.0" LOWER 1.35 RATIO



2010 DESERT STORM SHOOTOUT - 1ST PLACE - NATURALLY ASPIRATED SINGLE CAT
2009 DESERT STORM SHOOTOUT - 1ST PLACE - NATURALLY ASPIRATED SINGLE CAT
2008 DESERT STORM SHOOTOUT - 1ST PLACE - NATURALLY ASPIRATED SINGLE CAT

BOAT SPECS : 25 DAYTONA 680 HP SINGLE CARB
DRIVE SPECS : MMWX900 UPPER / WORX BILLET 2" SHT LOWER



2009 CATALINA SKI RACE - 1ST PLACE - UNLIMITED WOMENS
2007 CATALINA SKI RACE - 2ND PLACE - MENS CLASS

BOAT SPECS - 42 FOUNTAIN LIGHTNING
TWIN TEAGUE 900 HP

DRIVE SPECS - MMWX900 UPPERS / WORX MOD LOWERS

